

This heater is approved for industrial use only.



**SUPAGAS**  
YES WE CAN!

# Radiant Heater

## Safety warnings and operating instructions (please read all instructions carefully).

### Safety Warnings - (use only with LP Gas)

- The appliance is not designed for indoor residential use. **INDUSTRIAL USE ONLY**
- Installation must comply with local authority requirements.
- Minimum clearances MUST be maintained from combustible materials: 1000mm (top and front), 500mm (sides) and 300mm (rear) e.g. Overhead structures, walls, furniture, fixtures and plants.
- This appliance must only be used in a well ventilated area. Ventilation requirements must comply with AG601.
- This appliance must be placed on firm level ground.
- Do not install in very windy locations.
- Do not adjust the angle of the heater head – this will not only cause damage to the heater but is a fire hazard.
- Improper installation, adjustment, or alteration can cause personal injury, property damage, or even death.
- Do not transport or move appliance while it is operating.
- Do not expose the burners to water or moisture – heater must be protected from rain.
- If the appliance fails to operate correctly, contact place of hire or their authorised agent for advice and service. **DO NOT ATTEMPT REPAIRS YOURSELF**
- Do not place articles on or against this appliance.
- Do not store chemicals or flammable materials in the vicinity of this appliance.
- Do not spray aerosols or flammable materials in vicinity of appliance while it is operating.

Heater units direct their heat via infra-red rays which discharge the heat energy upon striking a surface. They do not pass through solid materials. When installing the unit, obstructions to the path of the rays must be considered from both a heating and safety point of view.

For the most efficient heating and safest working conditions, obstructions in the path of the heat rays should be avoided where possible. Ceiling clearance is also an important factor. Materials stored near the heater must be at a safe distance as the infra-red rays heat solid objects quickly



## WARNING

Do not adjust the angle of the heater head. Failing to comply may cause damage to the heater and is a fire hazard.

### Operating Instructions:

#### Turning the appliance on:

1. Before lighting, ensure the heater is situated on a firm level surface.
2. Set stand to full extended height and fix with bolt and nut provided.
3. Place 45kg gas bottle on stand and turn so that gas bottle valve is facing towards rear of heater. (This ensures that gas supply hose is clear of infra-red heat rays when heater is running). Retain with the safety chain provided.
4. Check the connection which screws into the LP Gas cylinder. Make sure the rubber seal is in position (end of the regulator) and not cracked or damaged in any way.
5. Screw regulator assembly to gas bottle and make sure connection is tight. This is a lefthand thread and turns counter clockwise to tighten.
6. Turn LP Gas cylinder valve counter clockwise to the **OPEN** position.
7. Check for leaks by applying soapy water (using non-ammonia based detergent) with spray bottle or soft cloth to LP Gas connections. A gas leak is indicated when bubbles appear in the soapy water.
8. Hold cord down for one second to allow gas into burners, then fully extend until a 'click' is heard. This will trigger a spark to ignite burners. A few attempts may be required.
9. After ignition, hold cord down for a further 20 seconds for the flame failure valve to set then release **SLOWLY**. Note: if cord is not released slowly the safety tip-over switch may activate and heater will not stay lit. When appliance is correctly turned on the tiles will start to glow red.

#### Turning the appliance off:

1. Turn LP Gas cylinder valve clockwise to the **CLOSE** position.



13 SUPA  
13 78 72  
supagas.com.au

This heater is approved for industrial use only.



**SUPAGAS**  
YES WE CAN!

# Radiant Heater

Please observe the following guidelines to minimum clearances required from combustibles

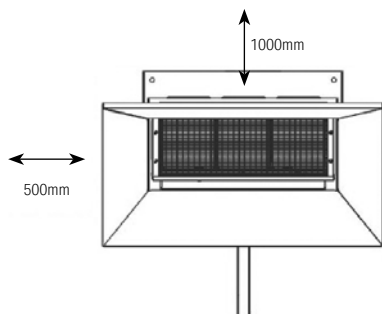

**Minimum Clearances from Combustibles  
(top and sides)**

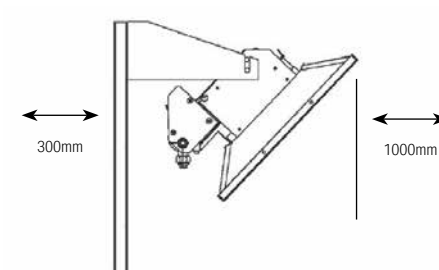

**Minimum Clearances from Combustibles  
(front and rear)**

NAT-HT11 Rev 4\_19032019



**13 SUPA**  
**13 78 72**  
supagas.com.au